

Neles Easyflow

JA series concentric disc
resilient seated butterfly valves
DN50 - DN600 (2" - 24")

Installation, maintenance and
operating instructions



Table of contents

GENERAL	3
Scope of the Manual	3
Wafer Body Design	3
Valve Markings	3
Safety Precautions	3
TRANSPORTATION AND STORAGE	3
INSTALLATION	4
General	4
Installing in the Pipeline	4
Flange bolt size and length tables	5
Flange bolt tightening torque	7
Operation and Actuator	7
Commissioning	7
MAINTENANCE	7
General	7
Actuated Valve	7
Valve Removal	8
Valve Disassembly	8
Checking Parts	8
Valve Assembly	8
Testing the Valve	9
ACTUATOR	9
Actuator Mounting Instructions	10
SERVICE / SPARE PART	10
EXPLODED VIEW	12
TYPE CODE	13

READ THESE INSTRUCTIONS FIRST!

These instructions provide information about safe handling and operation of the valve.

If you require additional assistance, please contact the manufacturer or manufacturer's representative.

SAVE THESE INSTRUCTIONS!

Addresses and phone numbers are printed on the back cover.

1. GENERAL

1.1 SCOPE OF THE MANUAL

This instruction manual contains important information regarding the installation, operation and maintenance of Neles Easyflow JA Series Concentric Disc Resilient Seated Butterfly Valves. Please read these instructions carefully and save them for future reference.

WARNING:

THE USE OF THE VALVE IS APPLICATION SPECIFIC. BE SURE THAT THE VALVE IS SUITABLE FOR ITS INTENDED SERVICE. IF YOU HAVE ANY QUESTIONS CONCERNING THE USE, APPLICATION OR COMPATIBILITY OF THE VALVE WITH THE INTENDED SERVICE, CONTACT VALMET FOR MORE INFORMATION.

WARNING:

IF THE VALVE DOES NOT HAVE A HANDLE OR AN ACTUATOR DO NOT PRESSURIZE. UNRESTRAINED DISC MAY OPEN OR CLOSE DUE TO PIPELINE PRESSURE.

1.2 WAFER BODY DESIGN

Some wafer designs contain flange bolt holes or slots in the body to hold the valve and assist with correct alignment with the flange during installation in the line. The centering holes or slots in wafer bodies alone are not suitable, or intended for containing line pressure, and are for use in conjunction with a fully bolted pipeline flange.

WARNING:

WAFER STYLE BODY BUTTERFLY VALVES MUST BE INSTALLED WITH A FLANGE ATTACHED TO THE DOWNSTREAM SIDE OF THE VALVE FOR DEAD-END OR END OF PIPELINE SERVICE. INSTALLING WAFER STYLE BODY BUTTERFLY VALVES AT THE END OF A PIPELINE WITHOUT ANY DOWNSTREAM PIPING OR FLANGES COULD LEAD TO UNCONTROLLED RELEASE OF PRESSURE, DAMAGE, OR PERSONAL INJURY!

1.3 VALVE MARKINGS

The valve has a label plate attached to the valve body (see **Figure 6**). The label plate markings identify the size, materials of construction, pressure rating, month and year of construction, and a unique serial and manufacturing order number for the valve.

1.4 SAFETY PRECAUTIONS

WARNING:

DO NOT EXCEED THE VALVE PERFORMANCE LIMITATIONS! EXCEEDING THE PRESSURE OR TEMPERATURE LIMITATIONS MARKED ON THE VALVE LABEL PLATE MAY CAUSE DAMAGE AND LEAD TO UNCONTROLLED PRESSURE RELEASE. DAMAGE OR PERSONAL INJURY MAY RESULT.

WARNING:

SEAT AND BODY RATINGS!

THE PRACTICAL AND SAFE USE OF THIS PRODUCT IS DETERMINED BY BOTH THE SEAL AND BODY RATINGS. READ THE LABEL PLATE. THE BODY AND TEMPERATURE RATINGS ARE DEPENDENT ON VALVE TYPE AND SEAL MATERIAL. DO NOT EXCEED THESE RATINGS!

WARNING:

BEWARE OF DISC MOVEMENT!

KEEP HANDS, OTHER PARTS OF THE BODY, TOOLS AND OTHER OBJECTS OUT OF THE OPEN FLOW PORT. LEAVE NO FOREIGN OBJECTS INSIDE THE PIPELINE. WHEN THE VALVE IS ACTUATED, THE DISC FUNCTIONS AS A CUTTING DEVICE. DISCONNECT ANY PNEUMATIC SUPPLY LINES, ANY ELECTRICAL POWER SOURCES AND MAKE SURE SPRINGS IN SPRING-RETURN ACTUATORS ARE IN THE FULL EXTENDED/RELAXED STATE BEFORE PERFORMING ANY VALVE MAINTENANCE. VALVE DISC IS KEPT IN CRACK OPEN POSITION PRIOR TO DISPATCH, SO THAT SEAL REMAINS IN UN-STRESSED CONDITION. FOR ACTUATED VALVES, USER MUST ADJUST ACTUATOR STOPPER BOLTS TO ENSURE SEAT LEAK TIGHTNESS BEFORE USE. FAILURE TO DO THIS MAY RESULT IN DAMAGE OR PERSONAL INJURY!

WARNING:

WHEN HANDLING THE VALVE OR VALVE/ACTUATOR ASSEMBLY, TAKE ITS WEIGHT INTO ACCOUNT!

NEVER LIFT THE VALVE OR VALVE/ACTUATOR ASSEMBLY BY THE ACTUATOR, POSITIONER, LIMIT SWITCH OR THEIR PIPING. PLACE LIFTING DEVICES SECURELY AROUND THE VALVE BODY. FAILURE TO FOLLOW THESE INSTRUCTIONS MAY RESULT IN DAMAGE OR PERSONAL INJURY FROM FALLING PARTS (SEE **FIGURE 1**).

2. TRANSPORTATION AND STORAGE

1. Check the valve and the accompanying devices for any damage that may have occurred during transport.
2. Store the valve carefully. Storage indoors in a cool, dry place. Less than 65% humidity is recommended.
3. Avoid direct exposure to sunlight.
4. The valve is delivered with the disc partially open about 10 degrees, and it should remain in this position during storage.
5. A light coating of Silicone grease is applied to the edge of the disc before packing at the factory. Do not remove valve from packaging until installation to protect from potentially harmful effects like dust and moisture. Do not leave valve unpacked for long periods of time
6. When in storage, it is recommended to operate the valve manually once every three months to maintain best performance.
7. Do not store near electrical equipment, motors or other equipment which may generate Ozone.
8. If the valve(s) are to be stored for a long duration, follow the recommendations of IMO-S1.

3. INSTALLATION

3.1 GENERAL

Remove packaging and check that the valve is clean inside.

Clean valve if necessary. Do not use diesel, thinner, or kerosene to clean the valve

CAUTION:

WHEN HANDLING THE VALVE OR THE VALVE PACKAGE, BEAR IN MIND ITS WEIGHT!

Follow the lifting methods shown in the **Figure 1**.

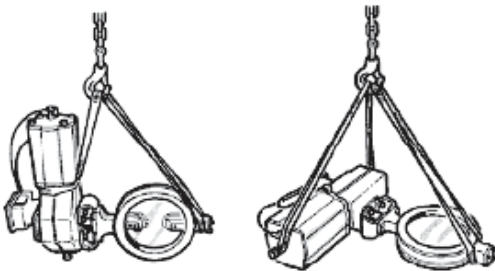

Figure 1. Lifting of the valve assembly

Flush the pipeline carefully before installing the valve. Foreign objects, such as dirt, sand, weld slag, or pieces of welding electrodes, will damage the disc and seal.

When installing the valve immediately after a pipe elbow, the valve shaft must be directed toward the center point of the pipe as is shown in the figure below. This is especially important when the valve is used as a control valve.

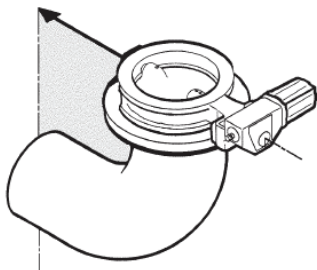

Figure 2. Mounting after a pipe elbow

The valve shaft of the butterfly valve mounted after a centrifugal pump must be perpendicular to the pump shaft as shown in the figure below.

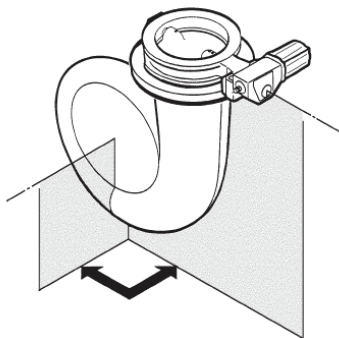

Figure 3. Mounting after a centrifugal pump

3.2 INSTALLING IN THE PIPELINE

WARNING:

BEFORE YOU INSTALL A BUTTERFLY VALVE IN, OR REMOVE IT FROM THE PIPELINE, CYCLE THE VALVE CLOSED. THE VALVE MUST BE INSTALLED IN THE CLOSED POSITION. FAILURE TO FOLLOW THESE INSTRUCTIONS CAN CAUSE MECHANICAL DAMAGE TO THE VALVE AND MAY RESULT IN PERSONAL INJURY.

WARNING:

THE VALVE SHOULD BE TIGHTENED BETWEEN FLANGES USING FASTENERS COMPATIBLE WITH THE APPLICATION, AND IN COMPLIANCE WITH APPLICABLE PIPING CODES AND STANDARDS. CENTER THE VALVE CAREFULLY BETWEEN FLANGES. DO NOT ATTEMPT TO CORRECT PIPELINE MISALIGNMENT BY MEANS OF FLANGE BOLTING!

WARNING:

GOOD PRACTICE DICTATES THAT ONCE INSTALLED, BUT PRIOR TO FIRST USE, THE VALVE IS LEAK TESTED IN PLACE TO ASSURE LEAK-TIGHTNESS HAS NOT BEEN COMPROMISED BY THE INSTALLATION PROCESS. PRESSURIZE THE PIPELINE AND CHECK FOR THROUGH LEAKAGE BETWEEN THE SEAL AND DISC AND EXTERNAL LEAKAGE AT THE FLANGE FACES.

CAUTION:

DO NOT USE FLANGE GASKETS. THE RUBBER SEAL EXTENDS FROM BOTH SIDES OF THE VALVE TO SEAL DIRECTLY AGAINST THE FLANGE FACES.

The valve may be installed in any position and offers tight shut-off in either flow direction.

1. Read all **WARNINGS!**
2. **IMPORTANT:** Actuator or handle stop must be used to stop the disc position. The valve itself does not have internal or external stops to limit disc rotation.
3. Before installing a valve in the pipeline, be sure that the actuator is attached so that clockwise rotation, viewed from above, closes the valve. Fully close the valve before installing in the pipeline.

CAUTION:

THE BUTTERFLY VALVE MUST BE CENTERED BETWEEN FLANGES TO AVOID DISC-PIPE CONTACT WHICH COULD DAMAGE THE DISC AND SHAFT. ANY FLANGE OR PIPELINE WELDING SHOULD BE DONE PRIOR TO INSTALLATION OF VALVES. IF THIS IS IMPOSSIBLE, PROTECTIVE COVERING OR SHIELDS MUST BE PLACED IN THE PIPELINE BETWEEN THE VALVE AND THE AREA BEING WELDED PRIOR TO WELDING. NOT ONLY MUST THE VALVE BE PROTECTED AGAINST WELD SLAG, BUT ALSO AGAINST ANY EXCESSIVE HEAT, WHICH COULD CAUSE SEAL DAMAGE. IT IS ESSENTIAL THAT ALL WELD SLAG, RODS, DEBRIS, TOOLS, ETC., BE REMOVED FROM THE PIPELINE BEFORE VALVES ARE INSTALLED OR CYCLED.

4. Secure the valve between flanges. Compress the flange seal EVENLY by tightening the fasteners in gradual steps in an alternating sequence as recommended per ASME PCC-1, Guidelines for Pressure Boundary Bolted Flange Joint Assembly. Recommended flange bolt tightening torques are given in **Section 3.4**.
5. After installation and pressure testing for leakage, operate the valve gradually from full close to full open to verify proper operation.

3.3 FLANGE BOLT SIZE AND LENGTH TABLES

NOTE: All fastener lengths are in millimeter and include a standard flat washer under each nut or rotating face as shown in the pictures.

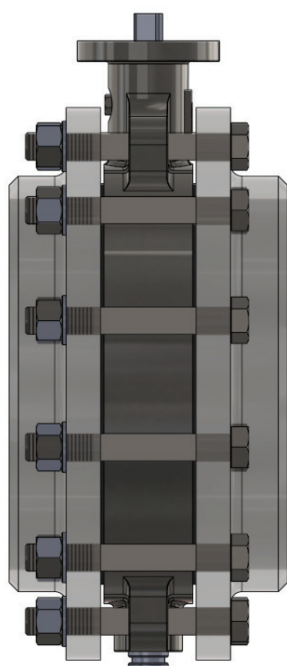

Figure 4.

Size		PN10							
DN	NPS	Bolt size	No. of A, B Bolts	A	B	Or, No. of C, D Bolts	C	D	T
50	2	M16	4	130	110	8	65	45	20
65	2 1/2	M16	4	130	110	8	65	45	20
80	3	M16	8	135	110	16	65	45	20
100	4	M16	8	145	120	16	65	50	22
125	5	M16	8	145	125	16	65	50	22
150	6	M20	8	160	135	16	75	55	24
200	8	M20	8	160	140	16	80	55	24
250	10	M20	12	175	150	24	80	60	26
300	12	M20	12	185	160	24	85	65	26
350	14	M20	16	195	170	32	90	65	30
400	16	M24	16	230	200	32	100	70	32
450	18	M24	20	250	220	40	110	75	36
500	20	M24	20	265	235	40	120	75	38
600	24	M27	20	310	280	40	130	85	42

Size		PN16							
DN	NPS	Bolt size	No. of A, B Bolts	A	B	Or, No. of C, D Bolts	C	D	T
50	2	M16	4	130	120	8	65	45	20
65	2 1/2	M16	4	130	120	8	65	45	20
80	3	M16	8	130	120	16	65	45	20
100	4	M16	8	140	130	16	70	50	22
125	5	M16	8	145	135	16	75	50	22
150	6	M20	8	160	140	16	75	55	24
200	8	M20	12	170	145	24	80	55	26
250	10	M24	12	190	165	24	90	60	29
300	12	M24	12	210	180	24	90	70	32
350	14	M24	16	210	185	32	95	70	35
400	16	M27	16	250	215	32	110	80	38
450	18	M27	20	270	240	40	110	90	42
500	20	M30	20	300	270	40	125	100	46
600	24	M33	20	350	320	40	145	110	55

Size		ASME B16.5 Class 150							
DN	NPS	Bolt size	No. of A, B Bolts	A	B	Or, No. of C, D Bolts	C	D	T
50	2	5/8-11UNC	4	135	110	8	70	50	20
65	2 1/2	5/8-11UNC	4	135	120	8	70	50	22
80	3	5/8-11UNC	4	140	130	8	70	50	24
100	4	5/8-11UNC	8	145	130	16	75	55	24
125	5	3/4-10UNC	8	160	140	16	80	55	24
150	6	3/4-10UNC	8	160	140	16	80	55	25
200	8	3/4-10UNC	8	170	150	16	85	60	28
250	10	7/8-9UNC	12	185	160	24	90	65	30
300	12	7/8-9UNC	12	200	180	24	90	70	32
350	14	1-8UNC	12	215	190	24	100	75	35
400	16	1-8UNC	16	240	220	32	110	80	37
450	18	1 1/8-8UNC	16	265	240	32	120	90	40
500	20	1 1/8-8UNC	20	285	260	40	120	90	43
600	24	1 1/4-8UN	20	330	300	40	130	100	48

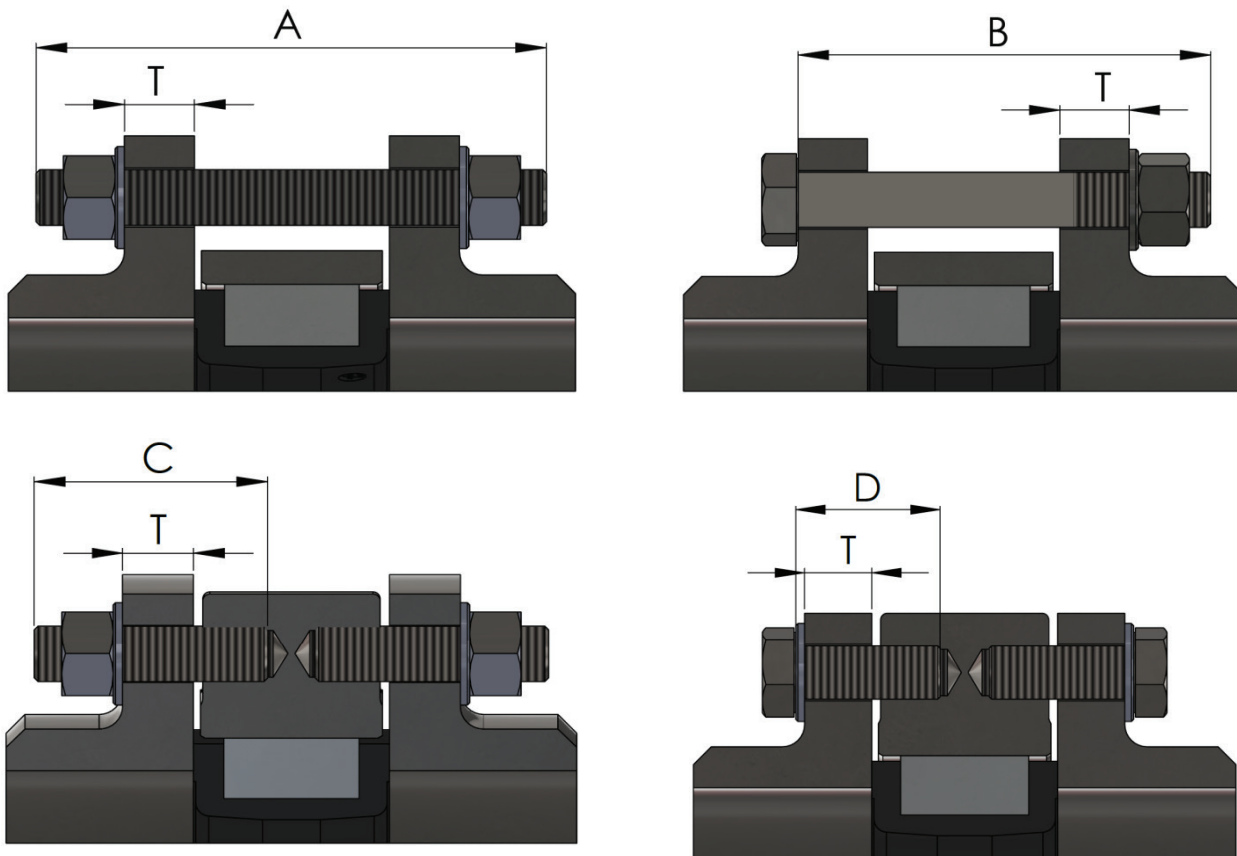

Figure 5.

Size		JIS10K							
DN	NPS	Bolt size	No. of A, B Bolts	A	B	Or, No. of C, D Bolts	C	D	T
50	2	M16	4	130	110	8	65	45	16
65	2 1/2	M16	4	130	110	8	65	45	18
80	3	M16	8	130	110	16	65	45	18
100	4	M16	8	135	120	16	70	50	18
125	5	M20	8	150	135	16	75	55	20
150	6	M20	8	155	140	16	80	55	22
200	8	M20	12	160	140	24	80	55	22
250	10	M22	12	175	155	24	85	60	24
300	12	M22	16	185	165	32	85	60	24
350	14	M22	16	190	170	32	95	65	26
400	16	M24	16	220	200	32	100	70	28
450	18	M24	20	240	220	40	110	75	30
500	20	M24	20	250	230	40	110	75	30
600	24	M30	24	295	270	48	120	85	32

Size		JIS16K							
DN	NPS	Bolt size	No. of A, B Bolts	A	B	Or, No. of C, D Bolts	C	D	T
50	2	M16	8	130	110	16	65	45	16
65	2 1/2	M16	8	130	110	16	65	45	18
80	3	M20	8	140	120	16	70	50	20
100	4	M20	8	150	130	16	75	55	22
125	5	M22	8	160	140	16	80	55	22
150	6	M22	12	160	145	24	80	55	24
200	8	M22	12	170	150	24	85	60	26
250	10	M24	12	190	170	24	95	65	28
300	12	M24	16	200	180	32	100	70	30
350	14	M30	16	220	200	32	110	80	34
400	16	M30	16	255	230	32	130	85	38
450	18	M30	20	270	245	40	130	90	40
500	20	M30	20	290	265	40	140	95	42
600	24	M36	24	335	310	48	150	105	46

3.4 FLANGE BOLT TIGHTENING TORQUE

NOTE: Torque values are for clean bolts with well lubricated threads and lubrication between nut and washer face.

Valve Size		Torque	
DN	NPS	ft-lb	N.m
50	2	30	40
65	2 1/2	30	40
80	3	35	50
100	4	40	55
125	5	45	60
150	6	50	65
200	8	55	75
250	10	75	100
300	12	110	150
350	14	120	160
400	16	120	160
450	18	125	170
500	20	125	170
600	24	150	200

3.5 OPERATION AND ACTUATOR

WARNING:

WHEN INSTALLING THE ACTUATOR ON THE VALVE, MAKE SURE THAT THE VALVE ASSEMBLY FUNCTIONS PROPERLY. INFORMATION ON ACTUATOR INSTALLATION IS GIVEN IN **SECTION 5** OR IN THE SEPARATE ACTUATOR INSTRUCTIONS.

WARNING:

BEFORE INSTALLING THE VALVE AND ACTUATOR, BE SURE THAT THE INDICATOR POINTER ON TOP OF THE ACTUATOR IS CORRECTLY INDICATING THE VALVE POSITION. FAILURE TO ASSEMBLE THESE PRODUCTS TO INDICATE CORRECT VALVE POSITION COULD RESULT IN DAMAGE OR PERSONAL INJURY.

WARNING:

FAILURE TO PROPERLY MOUNT THE HANDLE MAY RESULT IN IMPROPER VALVE OPERATION, DAMAGE OR PERSONAL INJURY MAY RESULT.

WARNING:

HIGH LINE PRESSURE MAY CREATE ENOUGH FORCES TO PULL THE MANUAL LEVER HANDLE OUT OF THE OPERATOR'S HAND.

1. The valve package should be installed in the pipeline in a manner that allows plenty of room for actuator removal.
2. The actuator must not touch the pipeline, because pipeline vibration may interfere with its operation.
3. Actuator mounting instructions are in **Section 5**.

3.6 COMMISSIONING

Ensure that there is no dirt or foreign objects left inside the valve or pipeline. Flush the pipeline carefully. Make sure that the valve is fully open when flushing.

Ensure that all nuts, fittings, and cables are properly fastened. If so equipped, check that the actuator positioner and/ or switch(s) are correctly adjusted. Actuator adjustment is explained in **Section 6**. To adjust any accompanying device(s) refer to the separate control equipment instruction manuals.

4. MAINTENANCE

WARNING:

BEFORE YOU REMOVE IT FROM THE PIPELINE, CYCLE THE VALVE CLOSED. THE VALVE MUST BE REMOVED IN THE CLOSED POSITION. FAILURE TO FOLLOW THESE INSTRUCTIONS WILL CAUSE MECHANICAL DAMAGE TO THE VALVE AND MAY RESULT IN PERSONAL INJURY.

4.1 GENERAL

Although Neles Easyflow valves are designed to work under severe conditions, proper preventative maintenance can significantly help to prevent unplanned downtime and reduce the total cost of ownership. Valmet recommends inspecting valves at least every five (5) years. The inspection and maintenance frequency depend on the actual application and process condition.

Overhaul maintenance consists of replacing the seal and bushings. These parts may be obtained from Valmet or an Authorized Valmet Distributor.

WARNING:

FOR YOUR SAFETY, IT IS IMPORTANT THE FOLLOWING PRECAUTIONS BE TAKEN PRIOR TO REMOVAL OF THE VALVE FROM THE PIPELINE OR BEFORE ANY DISASSEMBLY:

1. Be sure you know what fluid is in the pipeline. If there is any doubt, double-check with the proper supervisor.
2. Wear any Personal Protective Equipment (protective clothing or equipment) required when working with the fluid involved.
3. Depressurize the pipeline and drain the pipeline fluid. Differential pressure across and flow around a butterfly valve disc can cause the valve to open.
4. **NOTE:** Do not pressurize the valve without a handle or an actuator mounted on it! Do not remove a handle or an actuator from a valve under pressure! Damage or personal injury may result!
5. These valves are suitable for a wide variety of fluids and gases. Be certain that the valve materials replaced are suitable for the application.

4.2 ACTUATED VALVE

It is generally most convenient to detach the actuator and its auxiliary devices before removing the valve from the pipeline. If the valve package is small or if it is difficult to access, it may be more practical to remove the entire assembly.

NOTE: To ensure proper reassembly, observe the position of the

actuator and positioner/limit switch with respect to the valve before detaching the actuator.

WARNING:

ALWAYS DISCONNECT THE ACTUATOR FROM ITS POWER SOURCE, PNEUMATIC, HYDRAULIC OR ELECTRICAL, BEFORE ATTEMPTING TO REMOVE IT FROM THE VALVE!

WARNING:

BEWARE OF DISC MOVEMENT!

KEEP HANDS, OTHER PARTS OF THE BODY, TOOLS AND OTHER OBJECTS OUT OF THE OPEN FLOW PORT. LEAVE NO FOREIGN OBJECTS INSIDE THE VALVE OR PIPELINE. WHEN THE VALVE IS ACTUATED, THE DISC FUNCTIONS AS A CUTTING DEVICE.

WARNING:

DO NOT REMOVE A SPRING-RETURN ACTUATOR UNLESS A STOP-SCREW IS CARRYING THE SPRING FORCE!

1. Detach the air supply, electrical supply, hydraulic supply and control signal cables or pipes from their connectors.
2. Unscrew the actuator mounting screws.
3. Lift the actuator straight up in line with the valve stem until the connection between actuator drive and valve stem is completely disengaged.
4. Place actuator in a safe location to avoid damage or personal injury.

4.3 VALVE REMOVAL

1. Read all **WARNINGS!**
2. Valve must be fully closed before removing it from the pipeline.

CAUTION:

VALVES EQUIPPED WITH SPRING-TO-OPEN (AIR-TO-CLOSE) ACTUATORS MUST BE DISCONNECTED FROM THE ACTUATORS AND THEN CLOSED. VALVES MUST BE CLOSED WHILE REMOVING THEM FROM THE PIPELINE.

4.4 VALVE DISASSEMBLY

NOTE: It is good practice to replace the seal and bearings any time a valve is disassembled.

1. Read all **WARNINGS!**
2. Place the valve on a bench or other suitable working space.

WARNING:

REMOVING THE SHAFT WILL FREE THE DISC; THEREFORE, THE DISC MUST BE SUPPORTED TO PREVENT FALLING WHICH COULD RESULT IN DAMAGE OR PERSONAL INJURY!

3. Operate the valve so the disc is in the closed position
4. Remove the anti-blowout bolt (9) from the valve body (1).

5. Remove the spring dowel pin (6) and the bottom stem (4).
6. Remove the top stem (3) carefully.
7. Remove the seal (5) and disc (2) from the valve body (1).

CAUTION:

PROTECT THE DISC EDGE AT ALL TIMES TO AVOID DAMAGE.

4.5 CHECKING PARTS

1. Clean all disassembled parts.
2. Check the stems (3, 4) and disc (2) for damage. Pay particular attention to the sealing areas.
3. Replace any damaged parts.
4. Replace any parts that have cracks, gouges or pits that will affect sealing.

NOTE: When ordering spare parts, always include the following information:

- a. Valve type code as per technical bulletin and model number from name plate,
- b. If the valve is serialized – the serial number (stamped on the valve body or name plate) or applicable manufacturing order number,
- c. Spare part set number as per **Table 2**.

4.6 VALVE ASSEMBLY

Numbers in () refer to items shown in the exploded view

NOTE: Silicone grease may not be compatible with or permitted in the process application. Other non-petroleum based lubricants may be used that are compatible with the valve materials of construction and the process application.

1. Clean all valve components, if not previously done.

CAUTION:

THE USE OF A WIRE BRUSH, ABRASIVE PAPER/CLOTH, OR ANY SHARP OBJECT CAN DAMAGE THE SEAL.

2. Inspect all components for damage before assembling the valve. Look for damage to the sealing areas on the disc, stems, and body, and for wear in the bearing areas.
3. Carefully clean and polish the disc sealing surface. It should be free from all grooves and scratches.
4. If the disc is slightly damaged, it may be possible to smooth the sealing surface with fine emery cloth, a fine stone, or the equivalent. If deep scratches are present, replace the disc or return the valve to the factory for service.
5. Apply a light coating of Silicon grease to the seal inside diameter and the top and bottom stem holes.
6. Apply a light coating of Silicone grease to the disc edge.
7. Insert the bottom stem bushing (7) into the lower disc bore.
8. Insert the disc (2) into the seal (5).
9. Apply a thin coating of Silicon grease to the inside surface of the body (1) including the top and bottom stem holes.
10. Insert the seal (5) and disc (2) assembly into the valve body (1).
11. Apply Silicone grease to the bottom stem (4) and insert into the body bore and align the hole for the spring dowel (6). Drive the spring dowel (6) into position so it is equally engaged on both sides.

12. Install bushings (7) and spring rings (8) on the top stem (3). Apply Silicone grease and insert top stem assembly into the upper body bore. Ensure the line marked on top of the stem is aligned with the disc edge when engaging the stem and disc.
13. Install the anti-blowout bolt (9) in the valve body.
14. If the actuator was removed reinstall and set the actuator stops as described in the **ACTUATOR MOUNTING INSTRUCTIONS** Section.

4.7 TESTING THE VALVE

WARNING:

WHEN PRESSURE TESTING, EXERCISE CAUTION AND MAKE SURE ALL EQUIPMENT USED IS IN GOOD WORKING CONDITION AND APPROPRIATE FOR THE INTENDED PRESSURE.

WARNING:

GOOD PRACTICE DICTATES THAT ONCE INSTALLED, BUT PRIOR TO FIRST USE, THE VALVE IS LEAK TESTED IN PLACE TO ASSURE LEAK-TIGHTNESS HAS NOT BEEN COMPROMISED BY THE INSTALLATION PROCESS. INSTALLATION ACTIONS THAT CAN CAUSE LEAKAGE INCLUDE, BUT ARE NOT LIMITED TO; WRENCHING, SOLDERING, WELDING AND/OR HOISTING.

WARNING:

WHEN PERFORMING ANY TESTS, NEVER EXCEED THE MAXIMUM OPERATING PRESSURE OR MAXIMUM SHUT-OFF PRESSURE LISTED ON THE LABEL PLATE!

Should it become necessary to perform a leak test of the valve prior to its installation in the pipeline, follow the procedure outlined below.

1. Before pressurizing the valve be sure all actuator mounting fasteners are tight, and that the power or pressure is applied to the actuator to maintain the valve in the closed position.
2. The valve should be installed between flanges or in a testing apparatus. If flanges are used, refer to **INSTALLATION** Section. If a testing device other than flanges is used, the clamping force of the device must be comparable with flange bolt loads on the valve.
3. Partially open the valve. Verify that you do not have a seal between the seal and the disc. Exercise caution when cycling a valve in the test apparatus to avoid possible disc damage from the disc striking the test fixture.
4. Cap the downstream vent and apply the rated differential pressure to the valve. Check the shaft seals, and flange faces for leakage. This can be done by applying a liquid mixture of soap and water at all seal joints and watching for bubbles.

IMPORTANT: If leakage is detected between the valve and flanges **STOP IMMEDIATELY**. Mark the area of leakage. Vent the valve, and when it has returned to 0 psi (0 bar), retighten the flange bolts in the area. Pressurize the valve checking the flange again. If leakage persists, disassemble and inspect flange face and seal for damage.

5. If leakage is detected at the stem seals, vent the pressure, remove the valve, disassemble, and inspect for damage.
6. If the valve passes the external leak test, proceed with the following steps for internal seal leak test.

7. Vent the valve, and when it has returned to 0 psi (0 bar), cycle the valve closed.
8. Attach a small tube or hose to the downstream flange.
9. Be sure power/pressure is still applied to the actuator. Pressurize the upstream flange to the rated shut-off pressure. Check for leakage passing out through the free end of the tube/hose.
10. If leakage is detected, vent the pressure, cycle the valve open and close, and retest.
11. Pressurize the valve and check the leakage. If leakage cannot be stopped, adjust the closed position stop so that leakage is minimized, or disassemble and repair valve.

NOTE: Initial downstream movement of the disc can be mistaken for leakage. Wait at least 5 minutes after applying pressure before checking for leakage.

12. If the actuator has been removed, reinstall and set the actuator stops as described in the **ACTUATOR MOUNTING INSTRUCTION** Section. Do not install and tighten flanges on a newly resealed valve until the actuator stops are properly set and the valve is fully closed. Incorrect disc positioning may cause damage to a new seal when the valve is compressed between flanges for the first time. **NOTE:** After installation of a new seal, torque can be higher for a few cycles.

5. ACTUATOR

WARNING:

BEFORE INSTALLING THE VALVE AND ACTUATOR, BE SURE THAT THE INDICATOR POINTER ON TOP OF THE ACTUATOR IS CORRECTLY INDICATING THE VALVE POSITION. FAILURE TO ASSEMBLE THESE PRODUCTS TO INDICATE CORRECT VALVE POSITION COULD RESULT IN DAMAGE OR PERSONAL INJURY.

CAUTION:

WHEN INSTALLING OR SERVICING A VALVE/ACTUATOR ASSEMBLY, THE BEST PRACTICE IS TO REMOVE THE ENTIRE ASSEMBLY FROM SERVICE.

CAUTION:

AN ACTUATOR SHOULD BE REMOUNTED ON THE VALVE FROM WHICH IT WAS REMOVED. THE ACTUATOR MUST BE CHECKED AND READJUSTED FOR PROPER OPEN AND CLOSE POSITION EACH TIME IT IS REMOUNTED.

WARNING:

THE VALVE BODY AND MOUNTING INTERFACE HAS BEEN DESIGNED TO SUPPORT THE WEIGHT AND OPERATION OF NELES ACTUATORS AND RECOMMENDED ACCESSORIES. USE OF THIS INTERFACE TO SUPPORT ADDITIONAL EQUIPMENT SUCH AS PEOPLE, LADDERS, ETC. MAY RESULT IN THE FAILURE OF THE VALVE OR ACTUATOR AND MAY CAUSE PERSONAL INJURY.

WARNING:

WHEN MOUNTING THE ACTUATOR MAKE SURE THAT THE VALVE AND ACTUATOR ARE BOTH IN THE SAME POSITION. MOUNTING AN OPEN ACTUATOR TO A CLOSED VALVE COULD RESULT IN DAMAGE OR PERSONAL INJURY.

WARNING:

BEWARE OF DISC MOVEMENT!

KEEP HANDS, OTHER PARTS OF THE BODY, TOOLS AND OTHER OBJECTS OUT OF THE OPEN FLOW PORT. LEAVE NO FOREIGN OBJECTS INSIDE THE VALVE OR PIPELINE. WHEN THE VALVE IS ACTUATED, THE DISC FUNCTIONS AS A CUTTING DEVICE.

5.1 ACTUATOR MOUNTING INSTRUCTIONS

1. When a spring-return actuator is being mounted, the valve should be in the closed position for spring-to-close operation or in the open position for the spring-to-open operation. When an electric or double-acting pneumatic actuator is being mounted, the valve position should correspond to the indicated actuator position.
2. Assemble actuator onto the valve, ensuring full engagement between the stem and actuator drive, and the actuator fully contacts the mounting face on the valve.
3. Tighten actuator mounting screws to the torque listed in **Table 1**.

CAUTION:

THE USE OF A WIRE BRUSH, ABRASIVE PAPER/CLOTH, OR ANY SHARP OBJECT CAN DAMAGE THE SEAL.

CAUTION:

DO NOT EXCEED THE TIGHTENING TORQUE. APPLYING EXCESSIVE TIGHTENING TORQUE CAN DAMAGE THE ALUMINUM THREADS IN THE ACTUATOR BODY.

Table 1	
Torque to Aluminum Body Actuators	
Bolt Size	No Lubrication to Screws
mm	N.m
M6	6.8
M8	14.9
M10	30
M12	52
M16	122
M20	230

4. Cycle actuator and verify proper disc position in both open and closed positions. Adjust the actuator travel stops as necessary following instructions described in the actuator manual to these proper valves open and closed positions:

Valve Open:

Disc face perpendicular with the flange face.

Valve Closed:

Disc face parallel to flange face within 0.5 mm (0.020 inch).

6. SERVICE / SPARE PART

We recommend that valves be directed to Valmet service centers for maintenance. The service centers are equipped to provide rapid turn-around at a reasonable cost and offer warranty for reconditioning based on condition of each valve.

NOTE: When sending goods to the service center for repair, do not disassemble them. Clean the valve carefully and flush the valve internals. Include the material safety datasheet(s) (MSDS) for all media flowing through the valve. Valves sent to the service center without MSDS datasheet(s) will not be accepted.

For further information on spare parts and service or assistance visit our web-site at www.neles.com/products.

NOTE: When ordering spare parts, always include the following information:

- a. Valve type code as per technical bulletin and model number from name plate,
- b. If the valve is serialized – the serial number (stamped on the valve body or name plate) or applicable manufacturing order number
- c. Spare part set number as per **Table 2**.

7. WELDING WARNING

WARNING:

WELDING AND/OR GRINDING OF STAINLESS STEEL AND OTHER ALLOY STEELS CONTAINING CHROMIUM METAL MAY CAUSE THE RELEASE HEXAVALENT CHROMIUM. HEXAVALENT CHROMIUM, CHROMIUM(VI) OR CR(VI), IS KNOWN TO CAUSE CANCER. BE SURE TO USE ALL APPROPRIATE PPE WHEN WELDING METALS CONTAINING CHROMIUM. IF YOU HAVE ANY QUESTIONS CONSULT YOUR SUPERVISOR.

Table 2			
*Sign.1	Sign.2	Sign.3	Spare part sets
Valve size	Series	Seat material	Type codes (as applicable for each seal type)
50	JA	EP = Ethylene-Propylene (EPDM) NB = Nitrile (Buna-N, NBR) VT = Fluoroelastomer (FKM) SL = Silicone (VMQ) EW = White Ethylene-Propylene HN = Hydrogenated Nitrile (HNBR)	50 JAEP or 50 JANB or 50 JAVT or 50 JASL or 50 JAEW or 50 JAHN
65			65 JAEP or 65 JANB or 65 JAVT or 65 JASL or 65 JAEW or 65 JAHN
80			80 JAEP or 80 JANB or 80 JAVT or 80 JASL or 80 JAEW or 50 JAHN
100			100 JAEP or 100 JANB or 100 JAVT or 100 JASL or 100 JAEW or 100 JAHN
125			125 JAEP or 125 JANB or 125 JAVT or 125 JASL or 125 JAEW or 125 JAHN
150			150 JAEP or 150 JANB or 150 JAVT or 150 JASL or 150 JAEW or 150 JAHN
200			200 JAEP or 200 JANB or 200 JAVT or 200 JASL or 200 JAEW or 200 JAHN
250			250 JAEP or 250 JANB or 250 JAVT or 250 JASL or 250 JAEW or 250 JAHN
300			300 JAEP or 300 JANB or 300 JAVT or 300 JASL or 300 JAEW or 300 JAHN
350			350 JAEP or 350 JANB or 350 JAVT or 350 JASL or 350 JAEW or 350 JAHN
400			400 JAEP or 400 JANB or 400 JAVT or 400 JASL or 400 JAEW or 400 JAHN
450			450 JAEP or 450 JANB or 450 JAVT or 450 JASL or 450 JAEW or 450 JAHN
500			500 JAEP or 500 JANB or 500 JAVT or 500 JASL or 500 JAEW or 500 JAHN
600			600 JAEP or 600 JANB or 600 JAVT or 600 JASL or 600 JAEW or 600 JAHN
* leave space after Sign.1 Spare part sets common for PN10, PN16 and Class 150			

9. EXPLODED VIEW

DN 50 - DN 600

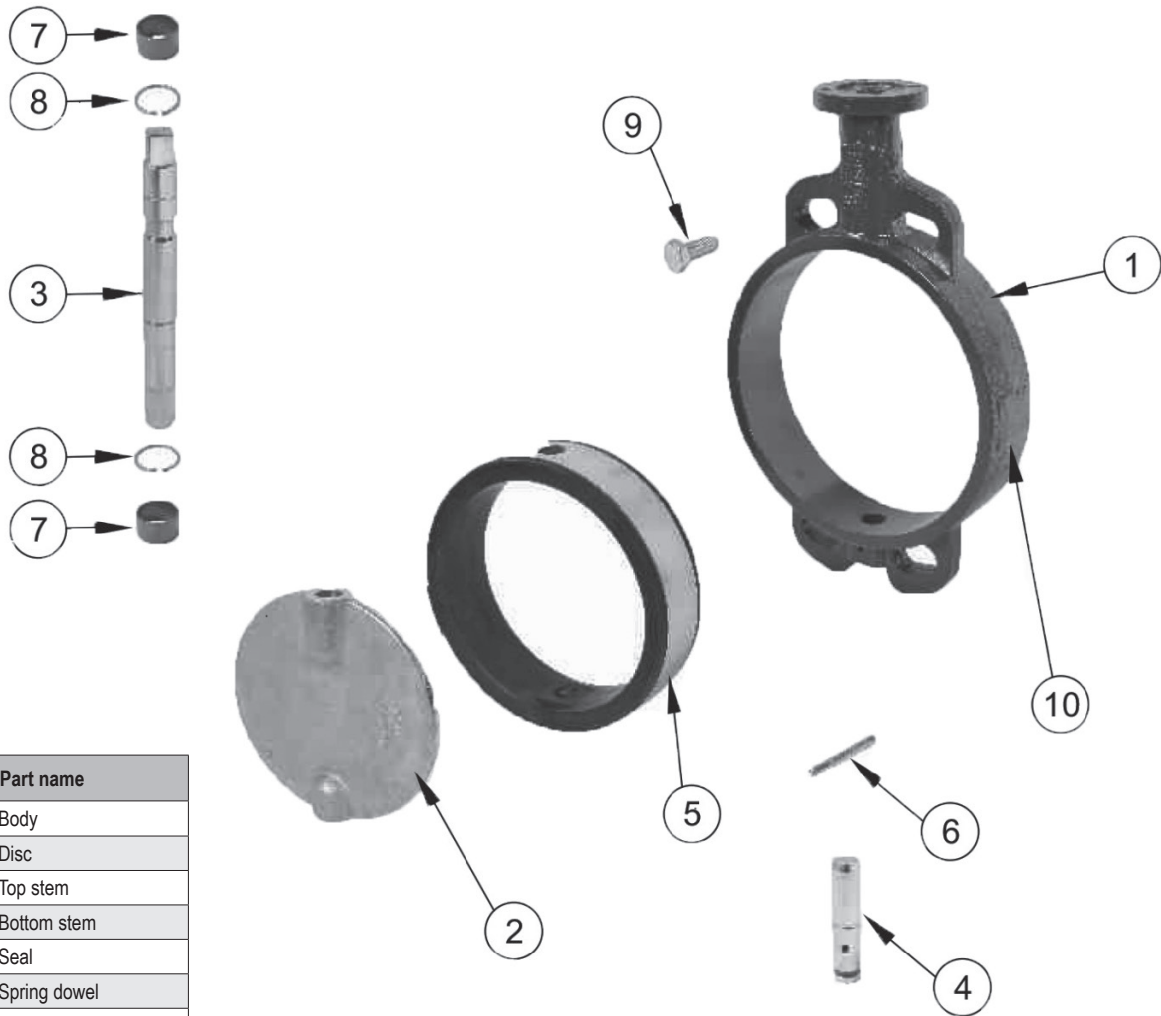

Part no.	Part name
1	Body
2	Disc
3	Top stem
4	Bottom stem
5*	Seal
6*	Spring dowel
7*	Bushing
8*	Spring ring
9	Anti-blowout bolt
10	Label

* These items form the spare part set.
Refer **Table 2** for spare part set details for each valve.

Figure 6.

10. TYPE CODE

NELES EASYFLOW JA SERIES BUTTERFLY VALVE

HOW TO ORDER

1.	2.	3.	4.	5.	6.	7.	8.	9.
200	JA	15	W	21	36	41	EP	

1. sign	Size, DN (NPS ref.)
50	50 (2)
65	65 (2 1/2)
80	80 (3)
100	100 (4)
125	125 (5)
150	150 (6)
200	200 (8)
250	250 (10)
300	300 (12)
350	350 (14)
400	400 (16)
450	450 (18)
500	500 (20)
600	600 (24)

2. sign	Series
JA	

3. sign	Flange / rating
10	PN 10
16	PN 16
15	ASME Class 150

4. sign	Body type
W	Wafer type
L	#Lug type

5. sign	Body material
21	GGG40 ductile iron
24	*GG25 cast iron
22	WCB carbon steel
36	CF8M stainless steel

* GG25 body option not available for Class 150

6. sign	Disc material
21	GGG40 ductile iron (epoxy coated)
36	CF8M stainless steel
12	#Bronze ASTM B148 C958

7. sign	Stem material
36	316 stainless steel
40	#S31803 Duplex Stainless
41	410 martensitic steel

8. sign	Seal
EP	Ethylene-Propylene (EPDM)
NB	Nitrile (Buna-N, NBR)
VT	#Fluoroelastomer (FKM)
SL	#Silicone (VMQ) (up to PN10 rating only)
EW	#White Ethylene-Propylene
HN	#Hydrogenated Nitrile (HNBR)

Non-standard options

9. sign	Non-standard options
P3	Low torque reduced diameter disc (undercut disc) with PN3.5 shut-off rating
P6	Low torque reduced diameter disc (undercut disc) with PN6 shut-off rating

NOTE: As the use of the valve is application specific, a number of factors should be taken into account when selecting a valve for a given application. Therefore, some of the applications in which the valves are outside the scope of this document. If you have any questions concerning the use, application or compatibility of the valve with the intended service, contact nearest Valmet sales office for more information.

Valmet Flow Control Oy

Vanha Porvoontie 229, 01380 Vantaa, Finland.

flowcontrol@valmet.com

Tel. +358 10 417 5000.

www.valmet.com/flowcontrol

Subject to change without prior notice.

Neles, Neles Easyflow, Jamesbury, Stonel, Valvcon and Flowrox, and certain other trademarks, are either registered trademarks or trademarks of Valmet Oyj or its subsidiaries in the United States and/or in other countries.

For more information www.neles.com/trademarks

