

Design:

Body	Flangeless wafer type
End Connection	EN 1092 PN 6, 10 and 16 ASME B16.5 cl. 150 / B16.47 cl. 150 MSS SP 44 cl. 150 AWWA C207 cl. B, D and E BS 10 table D and E JIS 5K/10K/16K
Face to Face	EN558-1/2 Series 20 API 609 Cat. A
Body Seat	Non replaceable Lining bonded to the body
Shaft Seal Design	O-ring bush
Driving Shaft	With indication for position of the disc
Special Design Options	-



Testing Procedures:

Shell strength test	EN 12266-1, P10 ISO 5208 API 598
Shell tightness test	EN 12266-1, P11 ISO 5208 API 598
Seat tightness test	EN 12266-1, P12, Rate A ISO 5208, Rate A API 598
Operability test	EN 12266-2, F20 ISO 5208 API 598

Options:

Anti-Static Design	In accordance with EN 736/3 and API 609
--------------------	--

Functional Characteristics:

Application	On/off, regulating, control valve
Design pressure PS	Maximum 16 bar
Design temp. TS	-20°C (-4°F) to +200° (392°F)
Flow velocity	Max. 5 m/s for liquids, max. 50 m/s for gases
Seat tightness rate	Bi-directional - ISO 5208 rate A

Marking & Certification:

Marking	EN 19, MSS SP 25
Certification	EN 10204 - 2.2, 3.1, 3.2

Product Data:

General Description	BUTTERFLY VALVE- Centric rubber lined
Design Code	EN 593
Size Range	DN 50 - 1400, NPS 2" - 56"
Maximum Pressure	10/16 bar - optional 20 bar for ≤ DN 600

Preferred position when installed in the horizontal pipeline

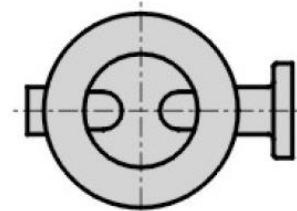

Parts List EVS 50-350 (2"-14"):

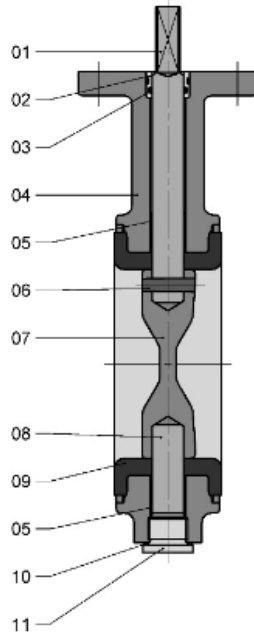

Item	Description	Material ⁽¹⁾	EN/DIN	Comparable ASTM
01	Shaft	Duplex SS Martensitic SS Aluminium Bronze Monel K500 Hastelloy-C	1.4462, EN 10088 1.4057, EN 10088 CuAl10Ni5Fe4, EN/DIN 17665 NA 18, BS 3076 -	A 182, Grade F51 A 276, Grade 431 B 150, C63000 - B 547, N10276
02	Bush	Bronze		
03	O-ring	EPDM NBR EPM		
04	Body	Cast Iron Ductile Iron Ductile Iron (low temp.) Carbon Steel Bronze	5.1301, EN 1561 (JL1040) 5.3106, EN 1563 (JS1030) 5.3103, EN 1563 (JS1049) 1.0619, EN 10213 2.1096.01, DIN 1705	A 126, Class B A 395, 60-40-18 - A216, WCB B 584, C.836.00
05	Bearing	St. / PTFE Lining Bronze / PTFE Lining		
06	Conical pin	See ITEM 01	See ITEM 01	See ITEM 01
07	Disc	Duplex SS Martensitic SS Ductile Iron / Rilsan coated ⁽²⁾ Aluminium Bronze Hastelloy-C	1.4462, EN 10088 1.4057, EN 10088 JS 1030, EN 1563 G-CuAl10Ni, DIN 1714 -	A 182, Grade F51 A 276, Grade 431 A 395, 60-40-18 B 148, C95800 A 494, CW-12MW
08	Shaft	CuNi	2.0835, DIN 17658	-
09	Lining	See ITEM 0 EPDM NBR FPM	See ITEM 0	See ITEM 0
10	Sealing ring	Cu		
11	Plug	St./Zn5C		

⁽¹⁾ Other materials on request

⁽²⁾ For DN 250 and DN 300

Dimensions EVS 50-350 (2"-14"):

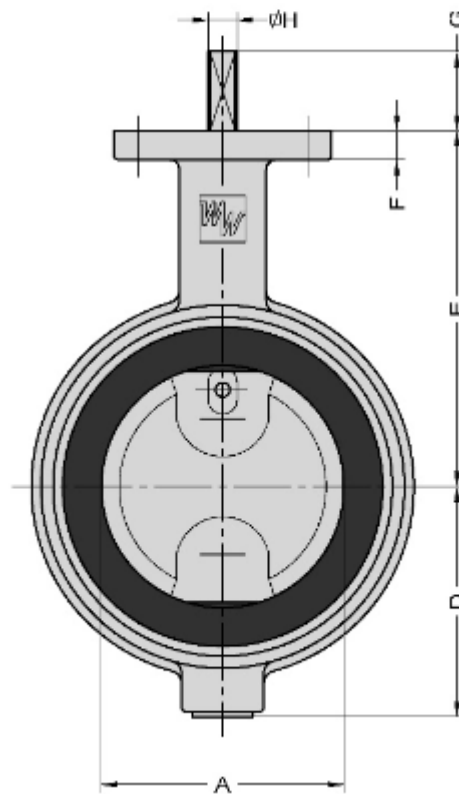
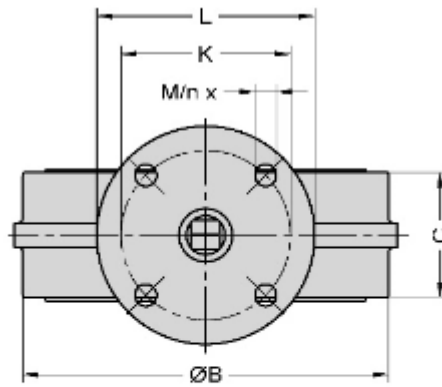

DN	NPS	A	B	C	D	E	F	G	H	ISO 5211	K	L	M	n	Mass ±kg
50	2"	50	100	43	63	118	12	34	10	F07	70	90	9	4	2.6
65	2 1/2"	65	115	46	71	126	12	34	10	F07	70	90	9	4	3.2
80	3"	80	130	46	78	133	12	34	10	F07	70	90	9	4	3.5
100	4"	100	150	52	96	147	12	34	12	F07	70	90	9	4	4.5
125	5"	125	182	56	109	160	12	34	12	F07	70	90	9	4	6.3
150	6"	150	210	56	133	180	14	34	16	F07	70	90	9	4	8.8
200	8"	200	262	60	158	204	14	34	16	F07	70	90	9	4	13.2
250	10"	250	315	68	194	245	15	45	24	F10	102	125	11	4	22
300	12"	300	371	78	219	270	15	45	24	F10	102	125	11	4	32
350	14"	336	405	78	236	315	15	45	24	F10	102	125	11	4	40

Parts List EVS 400-1000 (16"-40"):

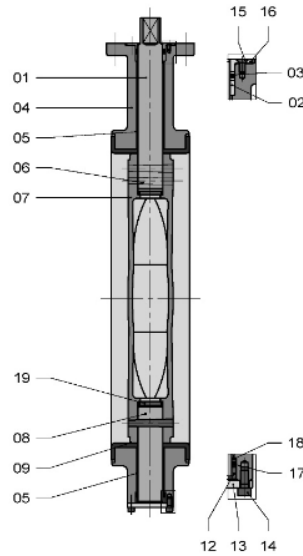

Item	Description	Material ⁽¹⁾	EN/DIN	Comparable ASTM
01	Shaft	Duplex SS Martensitic SS Aluminium Bronze Monel K500 Hastelloy-C	1.4462, EN 10088 1.4057, EN 10088 CuAl10Ni5Fe4, EN/DIN 17665 NA 18, BS 3076 -	A 182, Grade F51 A 276, Grade 431 B 150, C63000 - B 547, N10276
02	Bush	Bronze		
03	O-Ring	EPDM NBR EPM		
04	Body	Cast Iron Ductile Iron Ductile Iron (low temp.) Carbon Steel	5.1301, EN 1561 (JL1040) 5.3106, EN 1563 (JS1030) 5.3103, EN 1563 (JS1049) 1.0619, EN 10213	A 126, Class B A 395, 60-40-18 - A216, WCB
05	Bearing	St. / PTFE Lining Bronze / PTFE Lining		
06	Conical pin	See ITEM 01	See ITEM 01	See ITEM 01
07	Disc	Austenitic SS ⁽²⁾ Duplex SS ⁽³⁾ Martensitic SS ⁽⁴⁾ Ductile Iron / Rilsan coated Aluminium Bronze Hastelloy-C ⁽⁵⁾	1.4408, EN 10213 1.4462, EN 10088 1.4057, EN 10088 JS 1030, EN 1563 G-CuAl10Ni, DIN 1714 -	A 351, CF8M A 182, Grade F51 A 276, Grade 431 A 395, 60-40-18 B 148, C95800 A 494, CW-12MW
08	Shaft	CuNi See ITEM 01	2.0835, DIN 17658 See ITEM 01	- See ITEM 01
09	Lining	EPDM NBR FPM		
12	Axial bearing	Bronze		
13	Cover plate	St./Zn5C		
14	Cylinder head screw	St./Zn5C		
15	Counter sunk screw	St./Zn5C		
16	Collar bearing	Bronze		
18	Ring	Bronze		
19	Sealing plate	St./NBR St./FPM		

⁽¹⁾ Other materials on request

⁽²⁾ For \geq DN 500

⁽³⁾ forged \leq DN 450, casted \geq DN 500, material 1.4517, EN 10213 (ASTM A 351, CD-4MCu)

⁽⁴⁾ forged \leq DN 450

⁽⁵⁾ \leq DN 500

Dimensions EVS 400-1000 (16"-40"):

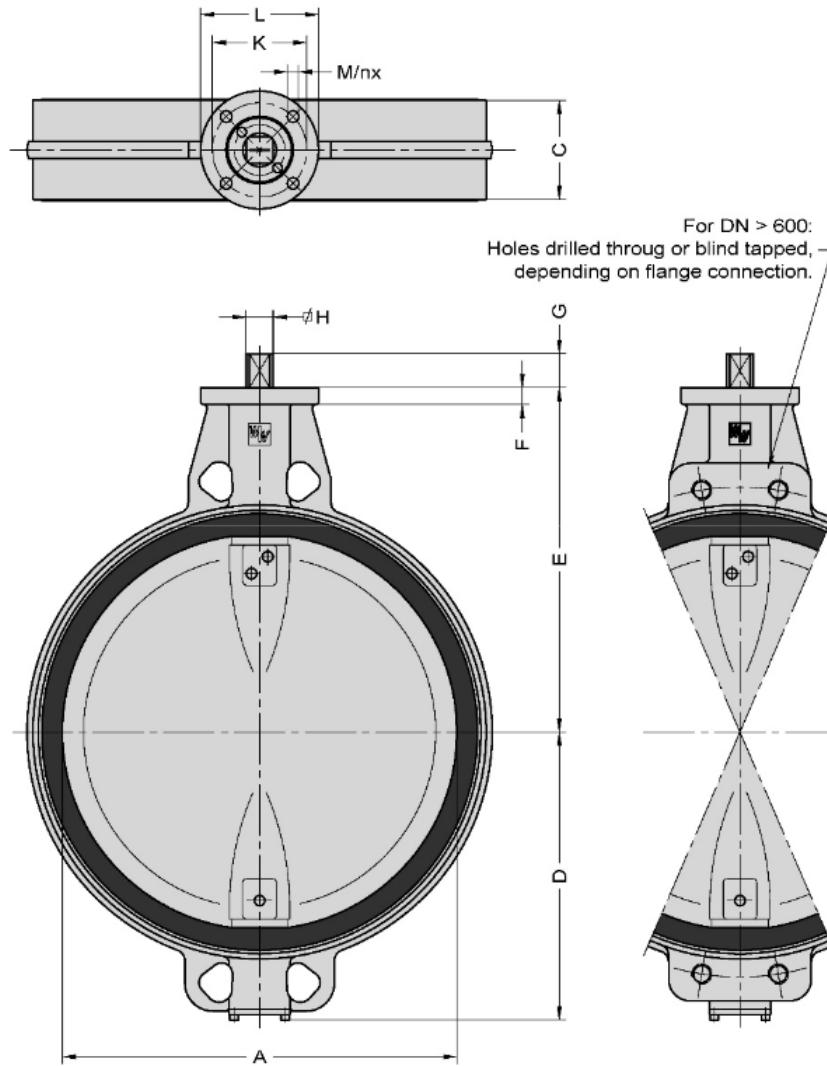

DN	NPS	A	B	C	D	E	F	G	H	ISO 5211	K	L	M	n	Mass ±kg
400	16"	386	470	102	308	363	25	50	30	F14	140	175	17	4	75
450	18"	436	522	114	334	388	25	50	30	F14	140	175	17	4	90
500	20"	486	576	127	360	413	25	50	30	F14	140	175	17	4	120
550	22"	536	630	154(*)	401	485	25	50	40	F14	140	175	17	4	165
600	24"	586	672	154	426	510	25	50	40	F14	140	175	17	4	180
650	26"	636	726	165(*)	474	535	25	60	46	F16	165	210	21	4	245
700	28"	686	776	165	499	560	25	60	46	F16	165	210	21	4	295
750	30"	736	826	190(*)	524	585	25	60	46	F16	165	210	21	4	295
800	32"	786	880	190	549	610	25	60	46	F16	165	210	21	4	345
900	36"	886	980	203	625	690	30	90	60	F25	254	300	17	8	475
1000	40"	986	1085	216	685	740	30	90	60	F25	254	350	17	8	635
1000	40"	986	1085	216	685	740	30	90	60	F30	298	350	21	8	635

(*) Manufacturer's standard

Parts List EVS 1200-1400 (48"-56"):

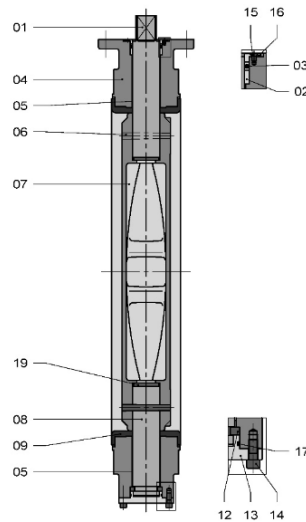

Item	Description	Material ⁽¹⁾	EN/DIN	Comparable ASTM
01	Shaft	Duplex SS Martensitic SS Aluminium Bronze Monel K500 Hastelloy-C	1.4462, EN 10088 1.4057, EN 10088 CuAl10Ni5Fe4, EN/DIN 17665 NA 18, BS 3076 -	A 182, Grade F51 A 276, Grade 431 B 150, C63000 - B 547, N10276
02	Bush	Bronze		
03	O-ring	EPDM NBR EPM		
04	Body	Cast Iron Ductile Iron Ductile Iron (low temp.) Stahl	5.1301, EN 1561 (JL1040) 5.3106, EN 1563 (JS1030) 5.3103, EN 1563 (JS1049) 1.0619, EN 10213	A 126, Class B A 395, 60-40-18 -
05	Bearing	St. / PTFE Lining Bronze / PTFE Lining		A216, WCB
06	Conical pin	See ITEM 01	See ITEM 01	See ITEM 01
07	Disc	Austenitiv SS Duplex SS Ductile Iron / Rilsan coated Aluminium Bronze	1.4408, EN 10213 1.4462, EN 10088 JS 1030, EN 1563 G-CuAl10Ni, DIN 1714	A 351, CF8M A 182, Grade F51 A 395, 60-40-18 B 148, C95800
08	Shaft	See ITEM 01	See ITEM 01	See ITEM 01
09	Lining	EPDM NBR FPM		
12	Axial bearing	Bronze		
13	Cover plate	St./Zn5C		
14	Cylinder head screw	St./Zn5C		
15	Counter sunk screw	St./Zn5C		
16	Flanged bush	Bronze		
17	O-Ring	EPDM NBR FPM		
19	Sealing plate	St./NBR St./FPM		

⁽¹⁾ Other materials on request

Dimensions EVS 1200-1400 (48"-56"):

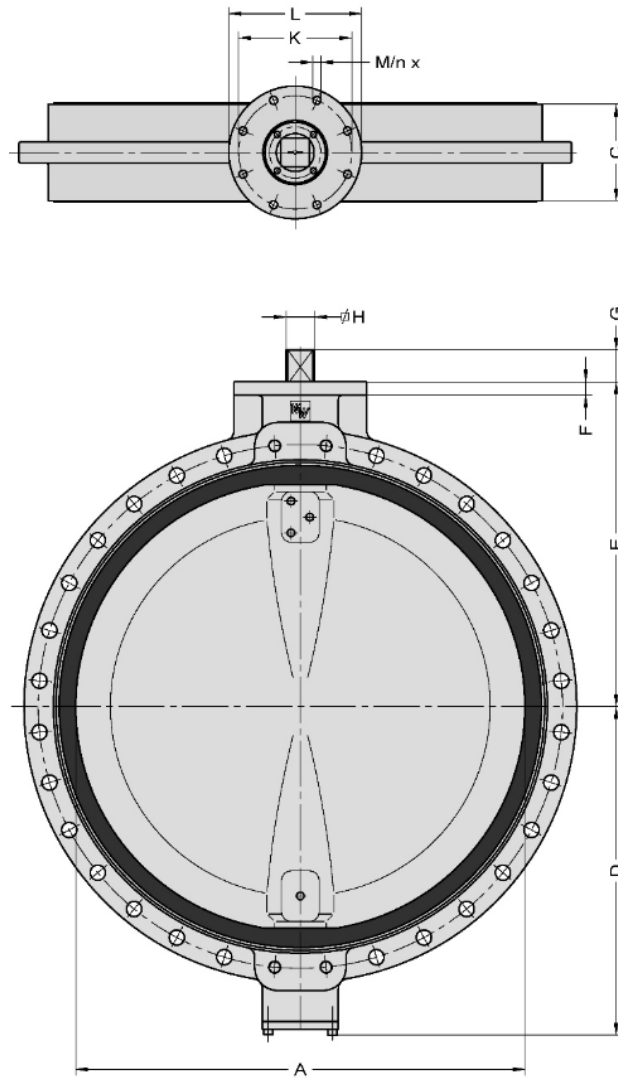

DN	NPS	A	B	C	D	E	F	G	H	ISO 5211	K	L	M	n	Mass ±kg
1200	48"	1186	1300	254	870	866	35	85	75	F30	298	415	21	8	1500
1200	48"	1186	1300	254	870	866	35	85	75	F35	356	415	31	8	1500
1400	56"	1386	1500	250(*)	980	966	35	85	75	F35	356	415	31	8	1900
1400	56"	1386	1500	250(*)	980	966	35	100	90	F35	356	415	31	8	1900

(*) Manufacturer's standard